



Market Code Schedule 17
Code Subsidiary Document No. 0204

Volume Processing and Estimation

Version: ~~1.11.2~~

Status: ~~Final~~

Date: ~~31/08/2007~~ 07/01/2009

Reference No: CSD0204

Change History

Version Number	Date of Issue	Reason For Change	Change Control Reference
1.0	14/05/2007		
1.1	31/08/2007		
<u>1.2</u>	<u>07/01/2009</u>	<u>Interim Meter Rollover Processes</u>	<u>MCCP019</u>

Table of Contents

1.	Purpose and Scope	3
2.	Volume Processing and Estimation	4
2.1	Using Meter Reads to calculate Actual Daily Volume	4
2.2	Estimation	8
2.3	Volume Derivation for Supply Points without Meters	9
3.	Process Diagrams	10
4.	Interface and Timetable Requirements	13
4.1	Volume Processing	13
4.2	Estimation	15
	Appendix 1 – Example Complex Supply Point calculations	16

1. Purpose and Scope

This document sets out the process by which the CMA will ascertain the Daily Volumes supplied to:

- Metered Supply Points, – including in relation to Single Meter, Multi Meter and Complex Site Supply Points ; and
- Unmeasurable and Measurable Supply Points, - in which case, the CMA will produce the Derived Daily Volume on the basis of the SPID Data and Scottish Water Data it holds in respect of the relevant Supply Point.

The CMA will use either the Actual or the Estimated Daily Volume supplied to each meter related to a Supply Point or the Derived Daily Volume for Unmeasurable and Measurable Supply Points when calculating volumetric charges payable in relation to a Supply Point in accordance with CSD 0205 (Charge Calculation, Allocation and Aggregation).

2. Volume Processing and Estimation

2.1 Using Meter Reads to calculate Actual Daily Volume

The CMA will calculate the Actual Daily Volume supplied to each meter related to a Supply Point when it receives a Meter Read in relation to that Supply Point. Either Scottish Water or any or each of the Licensed Providers will submit Meter Reads to the CMA, in accordance with CSD0202 (Meter Read Submission: Process).

2.1.1 Calculation of Actual Daily Volume

The CMA will calculate the Actual Daily Volume for each meter related to a Supply Point when a Meter Read for that meter is submitted to it.

Step 1

Subject to 2.1.2 below, the CMA will calculate the Meter Advance Volume by subtracting the value of any previous Meter Read for the relevant meter from the value of the latest Meter Read for that meter, as follows:

$$V_{MA} = R_L - R_P$$

Where:

V_{MA} is the Meter Advance Volume;

R_P is the value shown in the previous Meter Read; and

R_L is the value shown in the latest Meter Read.

Step 2

The CMA will then calculate the Actual Daily Volume (DV_A) supplied to the relevant meter by using the following formula:

$$DV_A = \frac{V_{MA}}{(D_2 - D_1)}$$

Where:

DV_A is the Actual Daily Volume for the Meter Advance Period;

V_{MA} is the Meter Advance Volume;

D_1 is the date of the previous Meter Read (i.e. the first date of the Meter Advance Period);

and

D_2 is the date the latest Meter Read (i.e. the last date of the Meter Advance Period).

After the Actual Daily Volume has been calculated it is then the subject of further validation, in accordance with CSD0203 (Meter Read Submission: Validation).

2.1.2 Meter Register Rollover Readings

Because all meters have a set number of digits, from time to time the value shown on a meter will return to 0000. Where such a meter register “rollover” occurs, (i.e. where the first two digits of the value of the previous Meter Read are '9' and the first two digits of the latest Meter Read are '0') the Meter Advance Volume will produce a high negative value. In such cases, the CMA will use the following equation to calculate the correct value for the Meter Advance Volume:

$$V_{MA} = (10^n - R_P) + R_L$$

Where:

V_{MA} is the actual Meter Advance Volume;

n is the number of digits on the meter;

R_P is the value of the previous Meter Read; and

R_L is the value of the latest Meter Read.

2.1.3 Preventing Undetected Meter Rollovers

Experience has shown that the algorithm in 2.1.2 above fails to detect a large number of meter register rollovers. Such undetected rollovers have a significant adverse impact on the accuracy of the Settlement Process. To mitigate such effects the following process shall be carried out every calendar month. It is acknowledged that in the initial months of operating this process that there may be a backlog of cases which require to be investigated. The Trading Parties shall use all reasonable endeavours to meet the timescales below.

Suspect Meter Read Histories

On a monthly basis, the CMA shall extract from the Central System a list of meters and meter reading histories which show a large negative advance, and which the CMA reasonably suspect that the Central System would not detect a meter register rollover. Additionally, in a number of cases the CMA might reasonably suspect that the number of digits registered against the meter is incorrectly held on the Central System.

Forwarding Meter Reading Histories

The CMA shall forward the extracts of the meter reading histories to the relevant Licensed Provider. Where the associated SPID has been transferred between Licensed Providers or

where the most recent read has been submitted by Scottish Water, then the CMA will forward the relevant extracts to all the relevant Trading Parties, who shall co-operate in undertaking the process below. In the case of the transfer of the SPID, the incoming Licensed Provider shall take the lead role in the investigation and be responsible for returning information to the CMA. In the case where Scottish Water has submitted the most recent read, Scottish Water shall take the lead role in the investigation and be responsible for returning information to the CMA. In either case reasonable extra time shall be allowed to facilitate co-operation between the Trading Parties.

Analysis of the Extracts

Within 5 Business Days of receipt of the meter history extracts, the Trading Party will either:

- Identify the meter reading history as a rollover; or
- Identify the meter reading history as suspect and requiring further investigation

and return details of the meter and meter reading identified as either a rollover or suspect to the CMA.

Meter Reading Histories Identified as Rollovers

Unless the CMA reasonably suspects that the meter reading history has been inappropriately identified as a rollover, then the CMA will:

- Create interpolated meter readings which would allow the Central Systems to properly identify a rollover;
- Upload these readings to the Central Systems; and
- Forward these readings by email to the relevant Licensed Provider and Scottish Water.

The interpolated readings will be of a distinctive value to facilitate identification, and will be uploaded to the Central Systems as “customer readings”. The interpolated readings and dates will be chosen to ensure that the Actual Daily Volumes over the interpolated period remain constant as far as possible.

If the CMA reasonably suspects that the meter reading history has been inappropriately identified as a rollover, then the CMA will return the reading to the Trading Party for further investigation.

Meter Reading Histories Identified as Requiring Further Investigation

Within 5 Business Days of a meter reading being identified as requiring further investigation, the Trading Party shall reasonably investigate further, and propose back to the CMA an appropriate remedy which might (without limitation) include:

- Identifying the meter reading as a rollover; or
- Proposing a retrospective amendment to the meter reading history; or
- Allowing the passage of time and further meter reads to reasonably correct the error.

Suspect Number of Meter Digits

Where the CMA reasonably suspects that the number of digits held against a meter on the Central System is incorrect, the CMA shall notify Scottish Water of all such cases. Within 5 Business Days of such notification, Scottish Water will investigate all cases and inform the CMA of the outcome of this investigation. Within a further 5 Business Days, Scottish Water will arrange to update the data held on the Central System where the data held has been identified as incorrect.

Impact on Performance Standards

Interpolated meter readings agreed and uploaded to the Central Systems in accordance with this process shall be completely excluded from the performance standards on meter readings.

2.1.3 2.1.4 Calculating Daily Volumes relating to Complex Sites

“**Complex Sites**” are any arrangement whereby two or more Supply Points are interdependent, in that, to derive Volume supplied in relation to one or more of the Supply Points, the CMA will require a Meter Read from both a Main Meter and Sub Meter(s) (which meters may not necessarily relate to the Supply Point in question).

Where:

Main Meter means the primary meter in relation to a Complex Site, there being only one such primary meter for each Complex Site; and

Sub Meter means a meter, the Volume supplied in relation to which, is a proportion of the Volume supplied in relation to a Main Meter.

A Deduced Daily Volume can be calculated by using a general formula:

$$DV_D = DV_{M1} - (DV_{M2} + DV_{M3} + DV_{M4...})$$

Where:

DV_D is the Deduced Daily Volume for the Complex Site Supply Point;

DV_{M1} is the Main Meter Daily Volume related to a Supply Point and SW network connection;

and

DV_{M2} , DV_{M3} and DV_{M4} are Sub Meter Daily Volumes related to other Supply Points.

In order to ensure that Meter Reads for meters related to Complex Sites are co-ordinated, the CMA will produce and distribute a meter reading schedule to Code Parties who in accordance with the Market Code will read and submit Meter Reads to the CMA to the agreed frequency.

Example configurations and calculations for Complex Sites are provided in Appendix 1.

2.2 Estimation

The CMA will calculate the Estimated Daily Volume supplied to each meter related to a Supply Point by using one of the following three methods:

First Level Estimation

Where the CMA has calculated the Actual Daily Volume supplied in relation to a meter in accordance with section 2.1.1. above, that calculation will remain valid for the Meter Advance Period. Following the Meter Advance Period the CMA will assume the same rate of Volume is supplied in relation to that meter and estimate the Estimated Daily Volume to be the same as the previous Actual Daily Volume. Where no previous Actual Daily Volume exists for any particular meter, the CMA will use either the second or third level estimations shown below.

Where a meter related to a Supply Point is changed in accordance with CSD0104 (Maintain SPID Data), the Estimated Daily Volume will be based on the old meter's Actual Daily Volume until an Actual Daily Volume is calculated for the new meter.

Second Level Estimation

In cases where the relevant Licensed Provider has provided the CMA with a forecast Estimated Yearly Volume in respect of a meter related to a Supply Point, the CMA will calculate the Estimated Daily Volume supplied to a meter using the following formula:

$$DV_E = YV_E / DIY$$

Where:

DV_E is the Estimated Daily Volume of a meter related to a Supply Point;

YV_E is the forecast Estimated Yearly Volume for the meter provided to the CMA by the relevant Licensed Provider; and

DIY is the number of days in the Year to which that forecast Estimated Yearly Volume relates.

Third Level Estimation

In cases where no Meter Read has been provided to the CMA in respect of a meter related to a Supply Point and the relevant Licensed Provider has not provided the CMA with a forecast Estimated Yearly Volume for that meter, the CMA will calculate the Estimated Daily Volume for that meter on the basis of the Chargeable Meter Size for that meter. This will be derived from an Industry Level Estimate Table that forms part of Market Domain Data.

The CMA will, using the equation shown for the second level estimation above, divide the applicable Estimated Yearly Volume shown in the Industry Level Estimate Table by the number of days in the relevant Year to calculate the Estimated Daily Volume for any relevant meter.

2.3 Volume Derivation for Supply Points without Meters

The CMA will perform the derivation of annual Volume for Unmeasurable and Measurable Supply Points in accordance with the conversion set out in the Scottish Water Data. The annual Volume for each Supply Point will then be converted into a Derived Daily Volume by dividing the annual volume by the number of days in that Year for use in volumetric charge calculations.

Where there is a transition from Measurable to metered the Derived Daily Volume will be used to derive the Estimated Daily Volume until it can be updated using a Meter Advance Period.

3. Process Diagrams

1. Volume Processing

Updated 17 Apr 2007

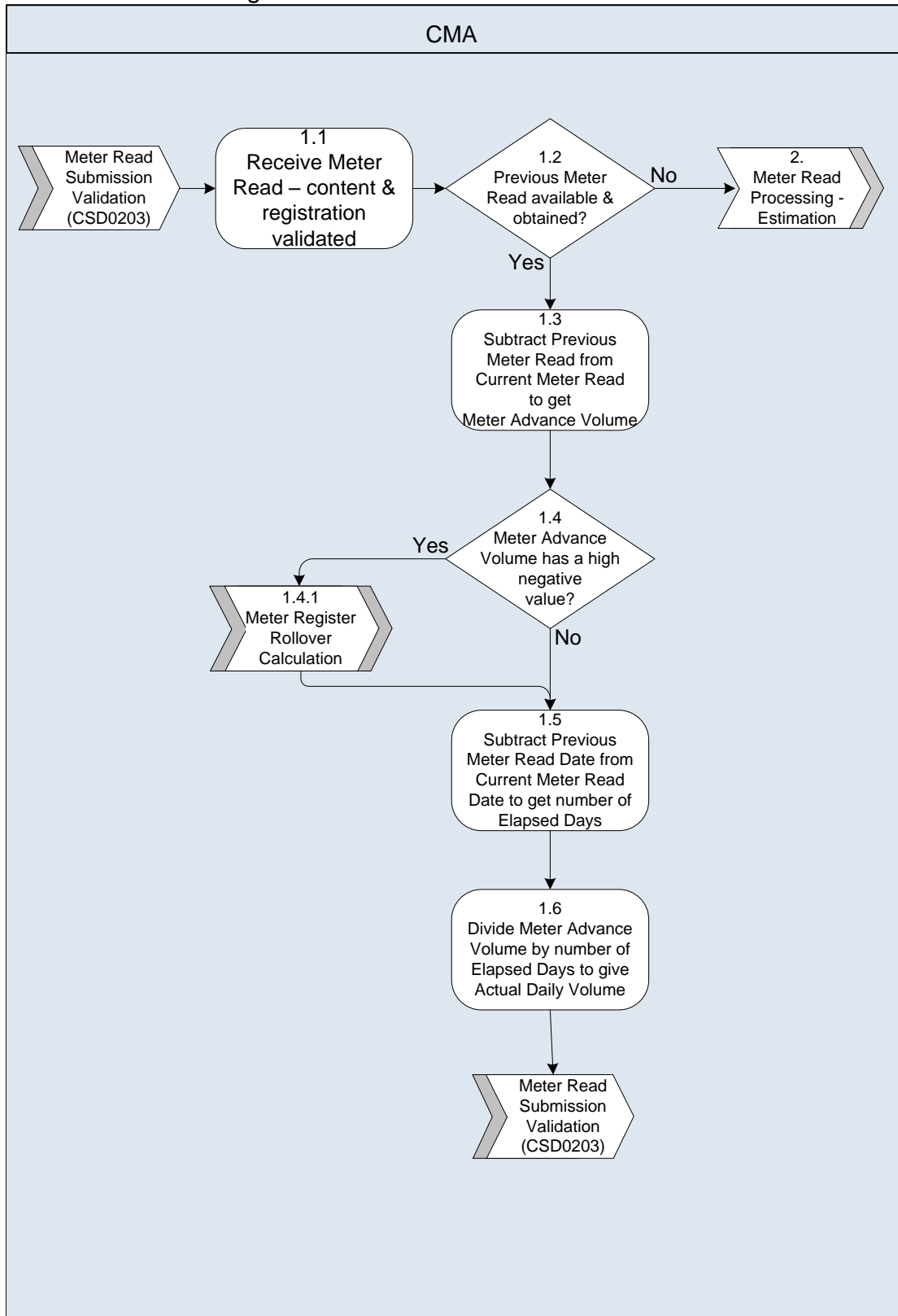

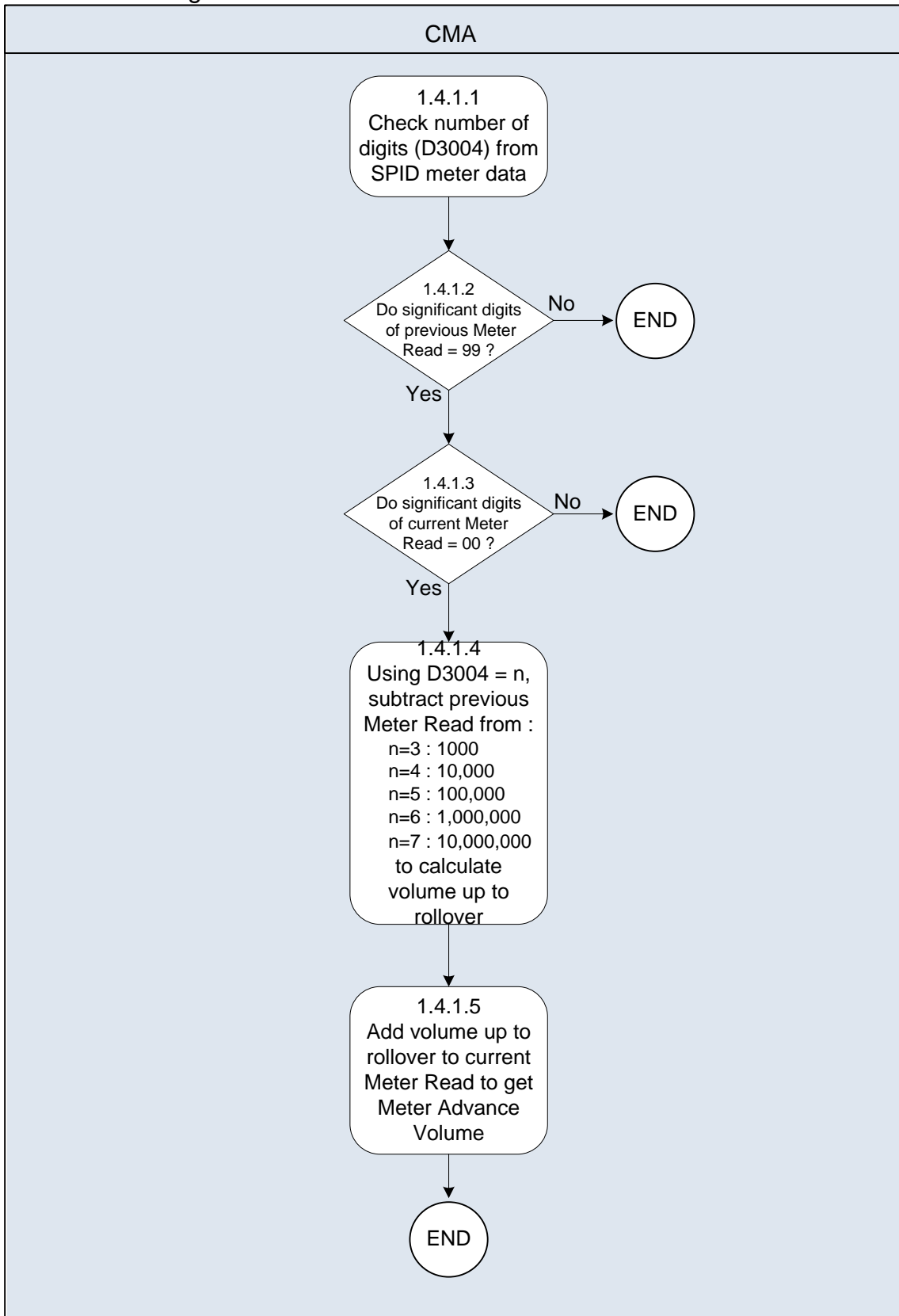

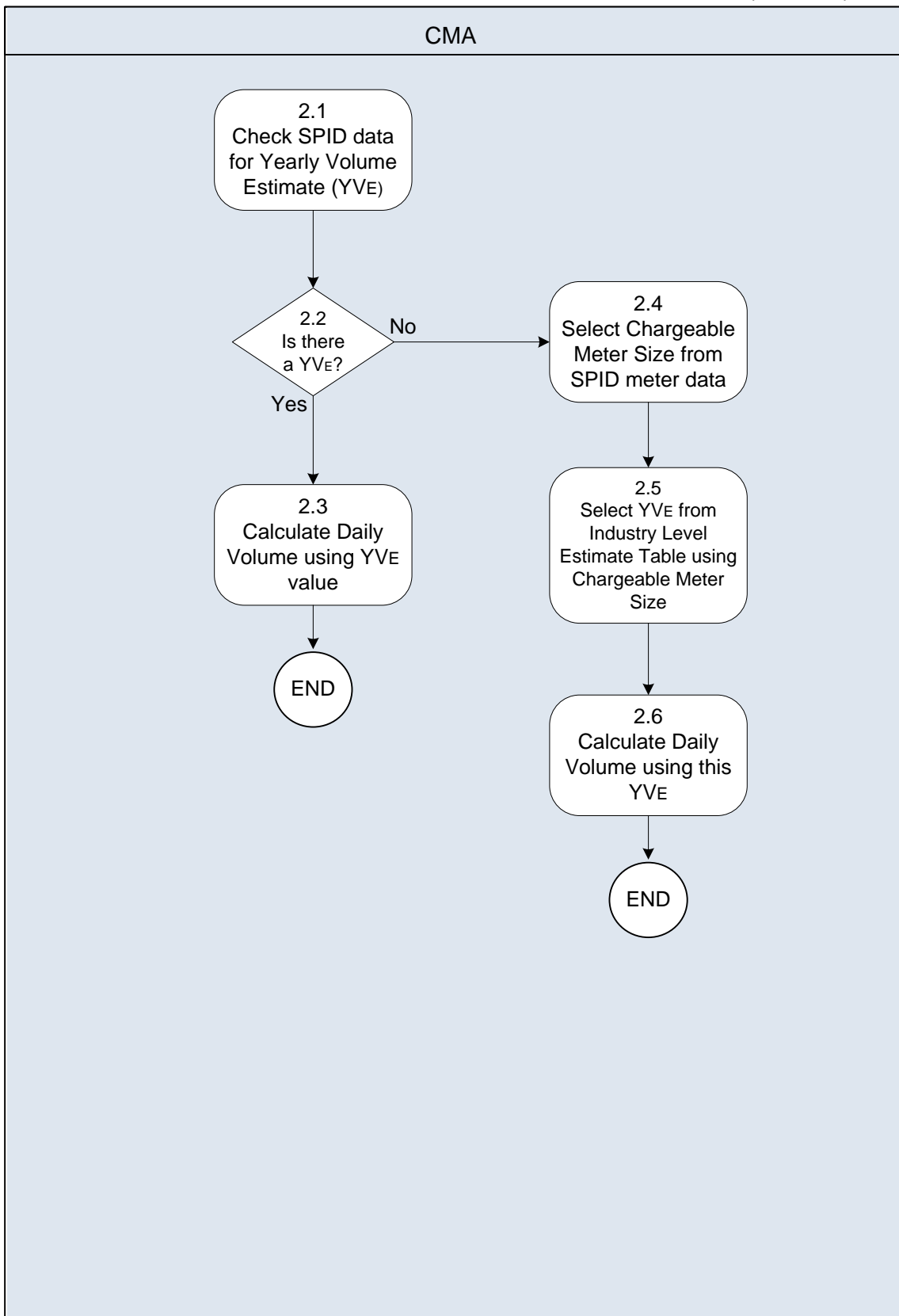

4. Interface and Timetable Requirements

4.1 Volume Processing

Step Ref	When	Requirement	From	To	Information	Method
1.1	On receipt	Receive each Meter Read from CSD0203 (Meter Read Submission: Validation)	CMA		For each Meter Read that passes Meter Read Submission Validation perform Registration and Content Validation SPID; meter Information; Meter Read ; the date of the Meter Read	CMA Internal
1.2		Retrieve the previous valid Meter Read for the relevant meter if available. If no Meter Read is available the process proceeds to stage 2, Estimation	CMA		The CMA will review the Standing Data for the relevant Supply Point to obtain the previous, validated, Meter Read. SPID; Standing Data for the Supply Point; meter Information; Meter Read; data of the Meter Read.	CMA Internal
1.3		Derive Meter Advance Volume	CMA		Subtract the previous Meter Read from the latest Meter Read to give the Meter Advance Volume. Previous Meter Read Latest Meter Read	
1.4		Meter register rollover check	CMA		If the Meter Advance Volume has a high negative value number, Perform 1.4.1 rollover read calculation or go straight to Step 1.5	
1.5		Calculate Meter Advance Period	CMA		Subtract the date of the previous Meter Read from the date of the latest Meter Read to give the number of days in the Meter Advance Period. Date of the previous Meter Read, Date of the latest Meter Read, number of days in the Meter Advance Period	
1.6		Calculate Actual Daily Volume and send to (Meter Read Submission: Validation) CSD0203	CMA		Divide the Volume supplied to the Meter during the Meter Advance Period by the number of days in the Meter Advance Period to produce the Actual Daily Volume Volume supplied to the meter over the Meter Advance Period, number of days in the Meter Advance Period, Actual Daily Volume	

4.1.1 Meter Register Rollover Calculation (stage 1.4.1)

Step Ref	When	Requirement	From	To	Information	Method
1.4.1.1		Obtain the number of digits used on the meter	CMA		This detail will assist in the recognition of a meter register rollover and will be part of the Registration Data held in respect of each meter that relates to each Supply Point Number of digits on the meter	
1.4.1.2		Roll over check and processing	CMA		If the first two digits in the value of the previous Meter Read, are not 9, a roll over is unlikely to have occurred and the current Meter Read should be verified 1.5.1.6	
1.4.1.3		Roll over check and processing	CMA		If the first two digits in the value of the current Meter Read, are not 0, a roll over is unlikely to have occurred and the latest Meter Read should be verified. Go to 1.4.1.6	
1.4.1.4		Calculate the Volume supplied to the meter during the Meter Advance Period	CMA		Using the number of digits used on the meter, subtract the value of the previous Meter Read from 1000 (if the number of digits used on the meter is 3), 10,000 (if the number of digits used on the meter is 4), 100,000 (if the number of digits used on the meter is 5) etc. This will provide the Volume supplied to the meter during the Meter Advance Period up to rollover.	
1.4.1.5		Produce recalculated Meter Advance Volume	CMA		Add the value of the Volume supplied to the meter during the Meter Advance Period up to rollover to the value of the current Meter Read to give the Meter Advance Volume. Go to 1.4.1.6	
1.4.1.6		End of Rollover Read Calculation	CMA		End of Process	

4.2 Estimation

4.2.1 Second and Third Level Estimation

Step Ref	When	Requirement	From	To	Information	Method
3.1		From the Standing Data, select the Licensed Provider's forecast provided Estimated Yearly Volume	CMA		Where the Licensed Provider has provided an Estimated Yearly Volume for the meter.	
3.2		If there is a Licensed Provider forecast Estimated Yearly Volume go to 3.3, otherwise go to 3.4	CMA			
3.3		Calculate the Estimated Daily Volume and the effective from date as the date of the latest Meter Read.	CMA		Estimated Daily Volume; effective from date, date of the latest Meter Read	
3.4		No Licensed Provider forecast Estimated Yearly Volume. From the Registration Data associated with the Supply Point to which the meter relates, select the Chargeable Meter Size	CMA		Chargeable Meter Size	
3.5		Using the Chargeable Meter Size select the Estimated Yearly Volume from the Industry Level Estimate Table.	CMA		Industry Level Estimate Table, Standing Data, Estimated Yearly Volume	
3.6		Calculate the Estimated Daily Volume and the effective from date as the date of the latest Meter Read			Estimated Yearly Volume, Estimated Daily Volume; effective from date	

Appendix 1 – Example Complex Supply Point calculations

At **Complex Sites** there may be a number of meters that the CMA will factor into its calculations of the Daily Volume supply to a Complex Site Supply Point. In the example configurations set out in this appendix, the meters that the CMA would factor into its calculations are upstream of the Complex Site Supply Point.

The Deduced Daily Volume is calculated by netting the Daily Volumes for each meter in relation to the Complex Site. The CMA will calculate the Daily Volume for each meter by using the formula provided in section 2.

A Deduced Daily Volume can be calculated by using a general formula:

$$DV_D = DV_{M1} - (DV_{M2} + DV_{M3} + DV_{M4} \dots)$$

Where:

DV_D is the Deduced Daily Volume for the Complex Site Supply Point;

DV_{M1} is the Main Meter Daily Volume related to a Supply Point and SW network connection; and

DV_{M2} , DV_{M3} and DV_{M4} are Sub Meter Daily Volumes related to other Supply Points.

Under the simplest scenario the meter arrangement would be M_1 and a secondary meter M_2 . This scenario is represented below.

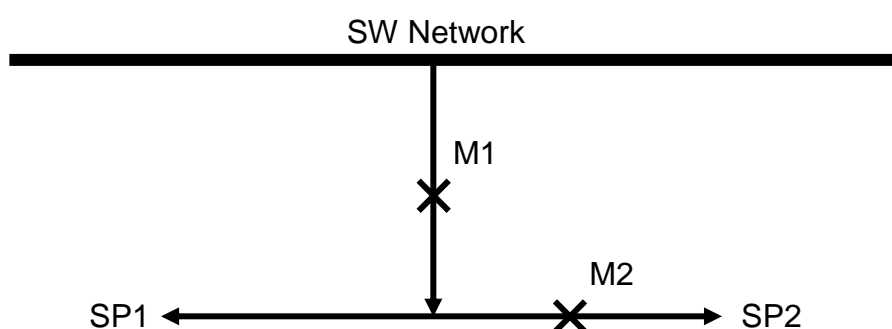

Figure 1. Representation of a complex site with different Meter Read requirements.

Under this situation represented in figure 1 the CMA would require Daily Volumes from M_1 and M_2 in order to calculate a Deduced Daily Volume for SP1. The following provides an example of the processing required.

$$DV_{M1} = 10\text{m}^3$$

$$DV_{M2} = 4.0\text{m}^3$$

DV_D is then calculated as follows:

$$DV_D = DV_{M1} - DV_{M2}$$

$$DV_D = 10 - 4$$

$$DV_D = 6.0\text{m}^3$$

Therefore, the Deduced Daily Volume for SP1 would be DV_D , a value of 6.0m^3 for the time period that the two Daily Volumes coincide with one another.

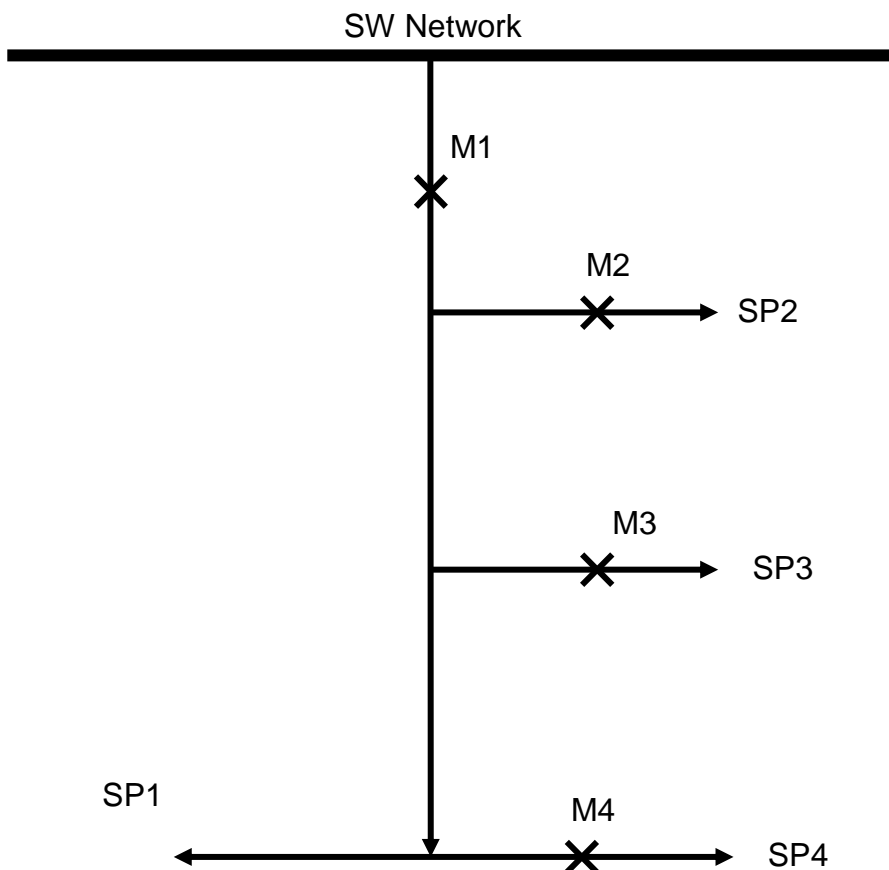

Figure 2. Representation of a complex site with different Meter Read requirements.

Under this situation represented in figure 2 the CMA would require Daily Volumes from M_1 , M_2 , M_3 and M_4 in order to calculate a Deduced Daily Volume for SP1. The following provides an example of the processing required.

$$DV_{M1} = 200\text{m}^3$$

$$DV_{M2} = 40\text{m}^3$$

$$DV_{M3} = 10\text{m}^3$$

$$DV_{M4} = 60\text{m}^3$$

DV_D is then calculated as follows:

$$DV_D = DV_{M1} - (DV_{M2} + DV_{M3} + DV_{M4})$$

$$DV_D = 200 - (40 + 10 + 60)$$

$$DV_D = 90\text{m}^3$$

Therefore, the Deduced Daily Volume for SP1 would be DV_D , a value of 90m^3 for the time period that the four Daily Volumes coincide with one another..